



Bearings for Steel Industry

2023 V1.0

LI-BE bearings deliver consistent, top-quality results every time maximizing your productivity and minimizing downtime.

CONTENTS

Introduction	5
Bearings for steel industry	7
Production	9
Design	15
Products	20
Virtual Visit	32

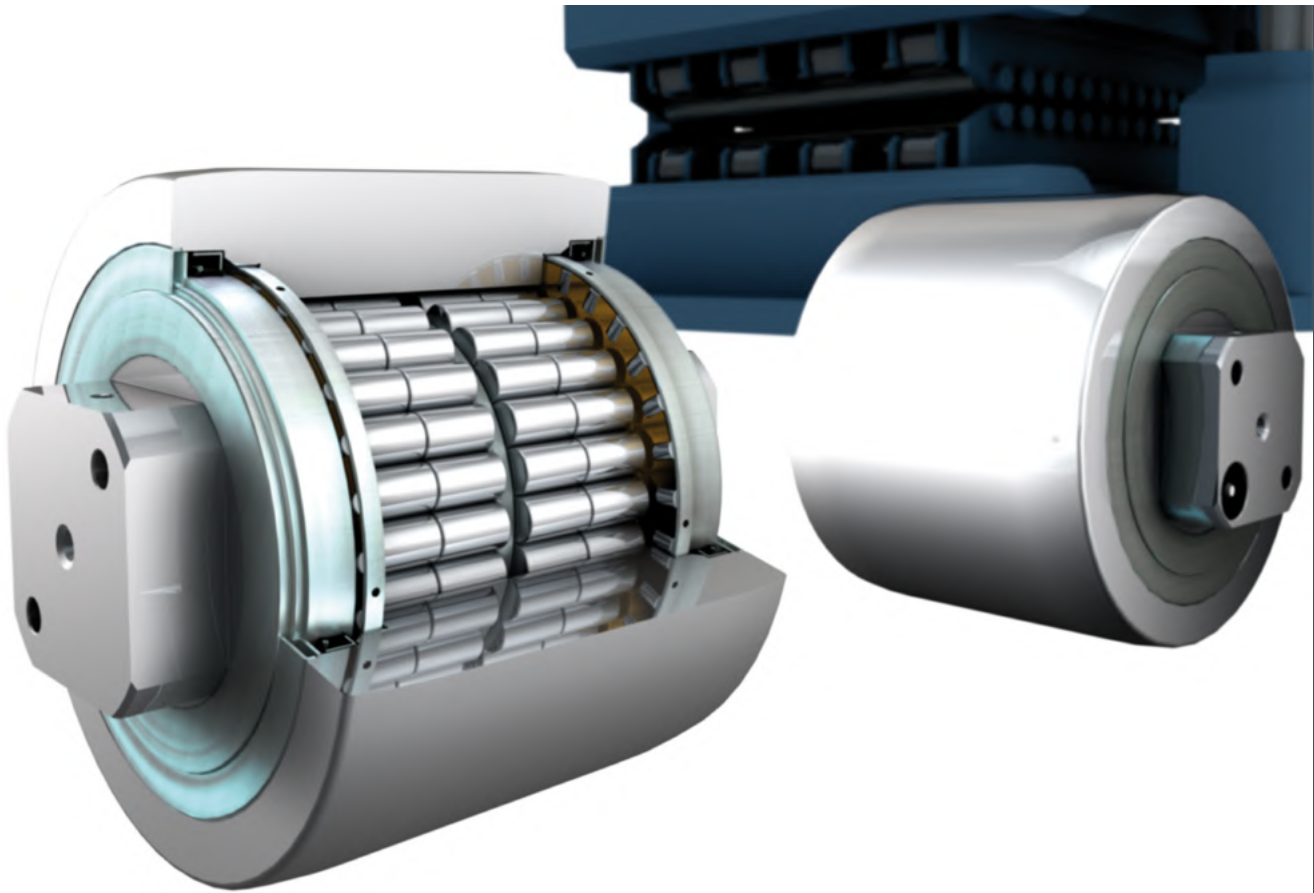

Established in 1984, LI-BE produces custom bearings, in terms of size and execution, for various industrial applications. LI-BE's strengths lie in the technical expertise and engineering of its design and production processes, which culminate in the SEL series of super-precision bearings for machine tools and customized products for the STEEL industry.

LI-BE has always been synonymous with special bearings and is the holder of some international patents.

For this reason the company uses a team of experts who are capable of providing solutions and projects which are suited to customers' specific requirements.

The foundation of LI-BE's technical development is rooted in the utilization of Digital Twin technology. By employing FEA and internal software within the Digital Twin, we are able to gain a comprehensive understanding of the effects of loads on bearings - knowledge that was once exclusive to only the most reputable manufacturers. Our CAM systems interpret 3D model geometries to direct the tool paths of lathes, milling machines, and 3D measuring machines, ensuring optimal geometries and high-quality standards.

LI-BE's exceptional products are a testament to our expertise and the drive to excel in an increasingly competitive industrial landscape, making us the ideal partner for high-tech solutions.

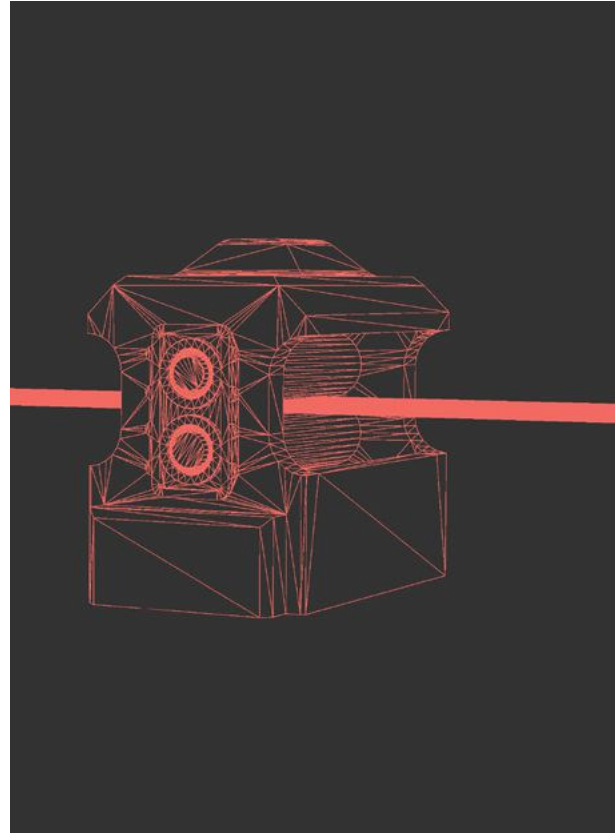
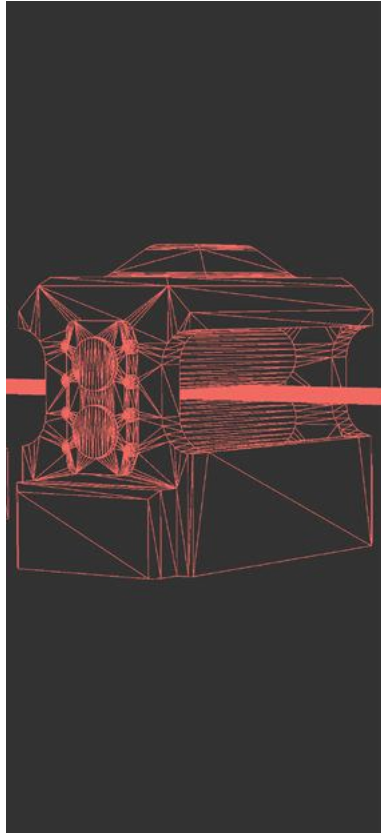
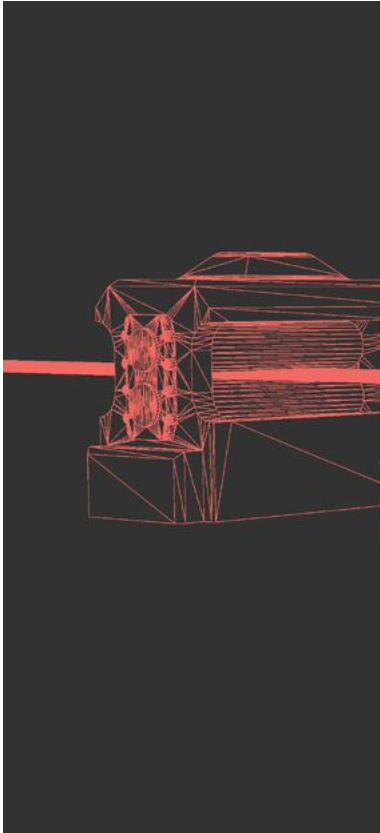

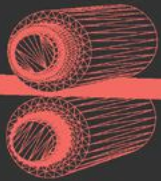

Bearings are key components in the steel industry

They are the cause of some **costly plant issues**:

- High maintenance costs
- Energy inefficiencies
- Unexpected and premature wear
- Poor quality of rolled products

LI-BE has developed a specialized process for the steel industry, focusing on key points of design and production. We can provide the most effective solution for you, increasing bearing life by up to 20% above standard values and improving uptime.

PRODUCTION

Our warehouse is entirely devoted to the production of bearings. Every stage of the process, except for heat treatment, is carried out by us in Italy to the highest standards of quality. Our entire production facility is monitored by a production management software capable of optimizing machine load and departmental control, providing real-time monitoring of process progress.





1-Turning and Milling department

Lathes with motorized tools and CNC machining centers are programmed using a CAM that communicates directly with project files through a dedicated PDM.

In-process control systems monitor tool wear to ensure high-quality, repeatable geometries.



2-Grinding department

We have 22 grinding machines capable of working on inner diameters, outer diameters, and faces, ensuring high precision during the final machining stages. The machines can handle diameters ranging from 20 mm to 1250 mm.

Marposs in-process and post-process control systems guarantee high quality and consistent geometries.



3- Quality

Our facility is equipped with a controlled atmosphere, dedicated measuring instruments, and 3D measuring machines to inspect both the finished components and machining processes. Thanks to the high level of specialization of our personnel, we can guarantee first-rate quality standards.



4- Isotropic finishing

For steel working applications that require optimal performance from their bearings, LI-BE's isotropic finishing is the ideal solution. Through our studies and analysis, we can estimate the real impact of this treatment on the bearing under load, resulting in an increased service life of approximately 20%. Another direct benefit of isotropic finishing is the improved efficiency of the bearings, minimizing the resistance torque and energy loss. Isotropic finishing is particularly advantageous for systems without driving rollers.

DESIGN

A rough analysis in the design process can over/under estimate the real characteristic of the bearing in its working condition under loads.

In the steel industry, with massive loads and really hard working condition, an accurate design process can prevent some major problems in your steel working plant, preventing failure and increasing the uptime.

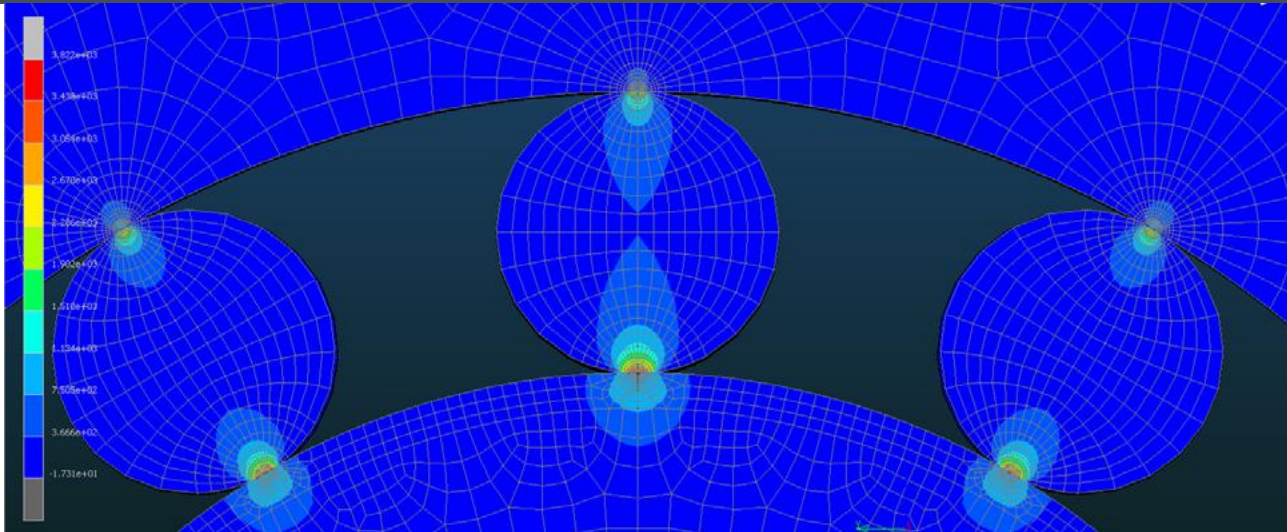

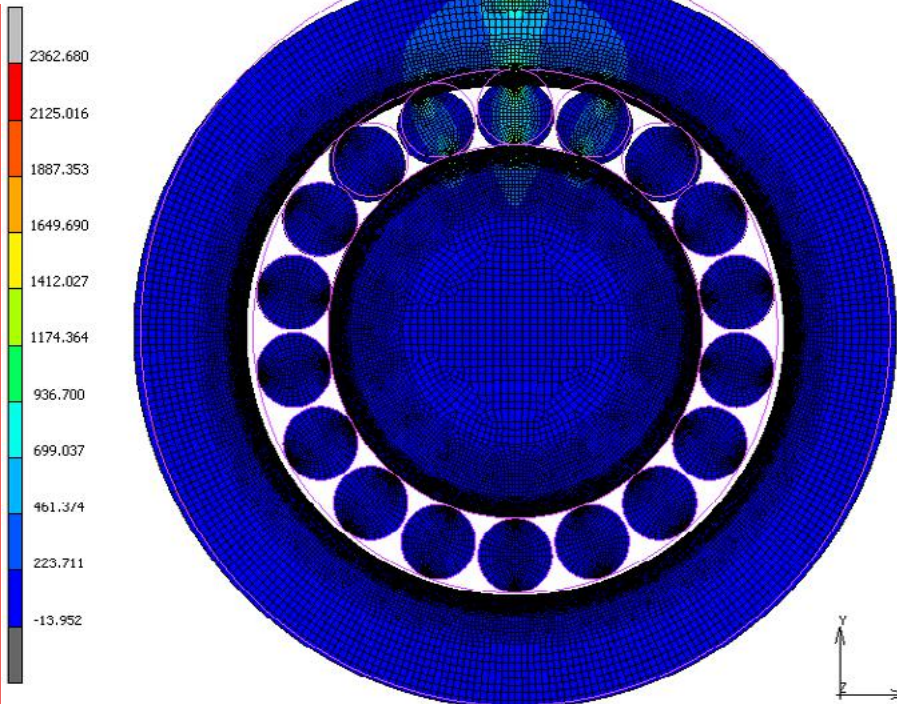

Icase3_1
Equivalent Von Mises Stress

1-Elastic outer ring

Under high load, even the biggest outer ring will be deformed and so the distribution of force between ring and rollers will change.

The deformation of the outer ring can be calculated for any shape. Contacts between lamination roll and the outer ring can be taken into account to help customers in their design process.

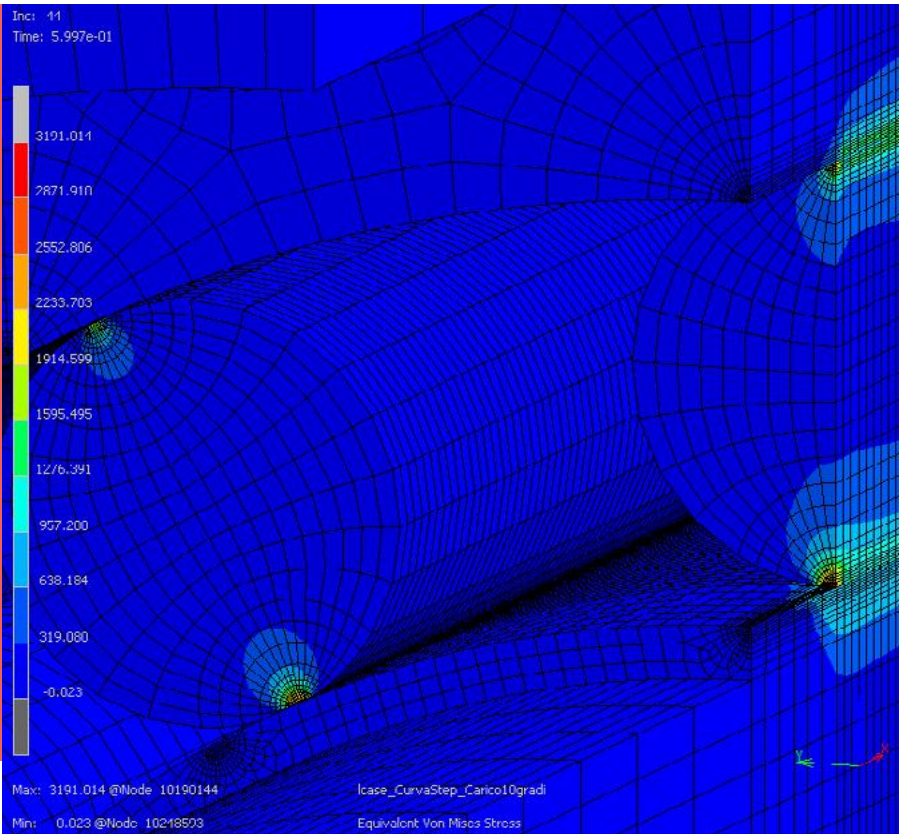

2-Contact pressure local analysis

Rollers contacts on the raceway generate local wear peaks.

Thanks to our dedicated software (based on ISO/TS 16281) and thanks to FEM analysis we can identify and solve this problem.

Also the smallest variation in contact pressure due to rollers profile can be easily investigated.

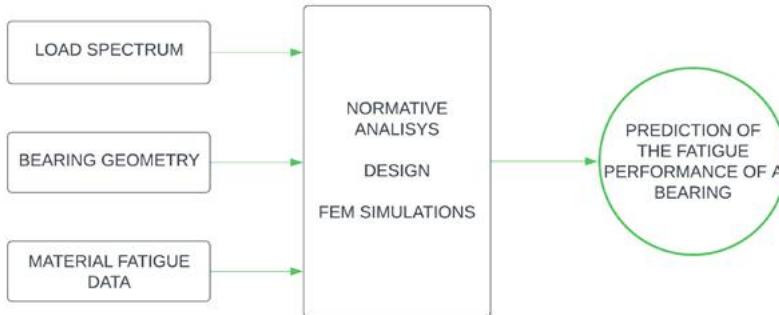
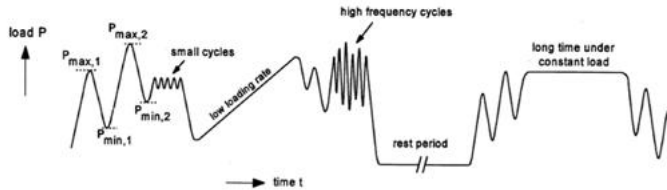

3-Load spectrum analysis

Many calculation systems only consider the mean value of the applied load, overestimating or underestimating the bearing life. This results in higher costs due to preventive oversizing of bearings, or even worse, bearing failure and plant downtime. This is especially true in the field of steel industry, where peak loads represent a significant component. This is the reason why at LI-BE we analyze the entire load spectrum, allowing us to obtain a much more realistic estimation of bearing life.

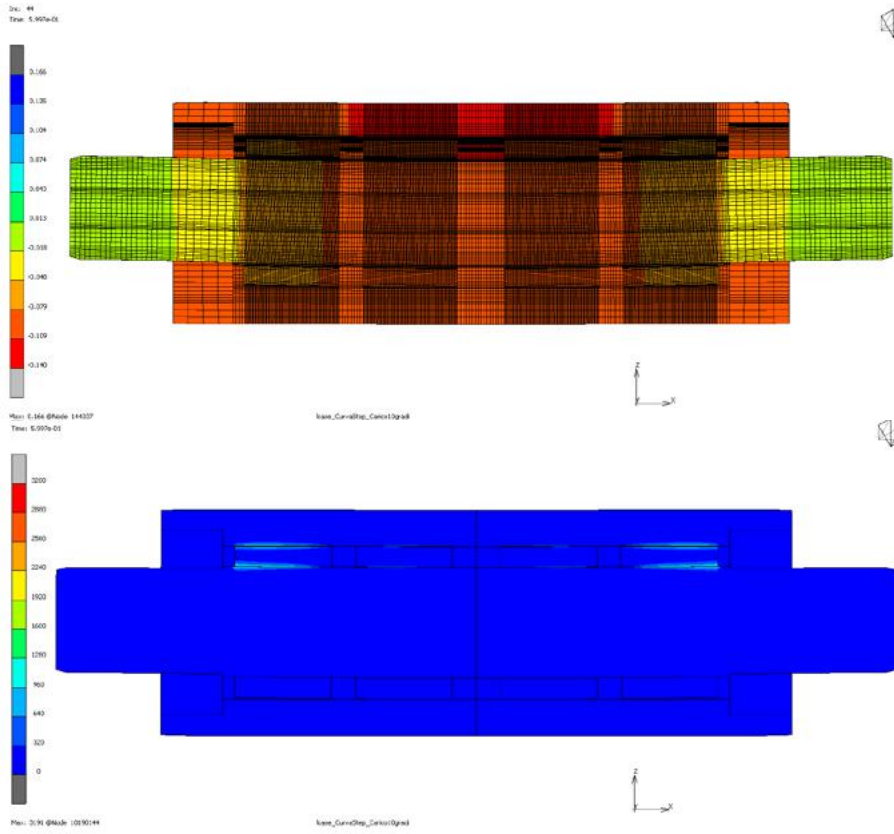

4-Shaft Deflection

The bending of the shaft causes load imbalance on the rollers, leading to contact pressure spikes that significantly reduce the bearing's lifespan and load capacity. Unfortunately, even the most up-to-date standards such as UNI/ISO 16281 do not take this issue into account. At LI-BE, we are capable of simulating, through FEM analysis, the correct load distribution on the rollers, providing us with the necessary information to determine the bearing's survival probability with great precision.

PRODUCTS

LI-BE is experienced in designing and building custom solutions for the steel industry.

Don't hesitate to contact us if you don't find the ideal solution for you among these pages, where the most requested bearing families are summarized. Our team will guide you in choosing the most suitable technical solution for your needs.

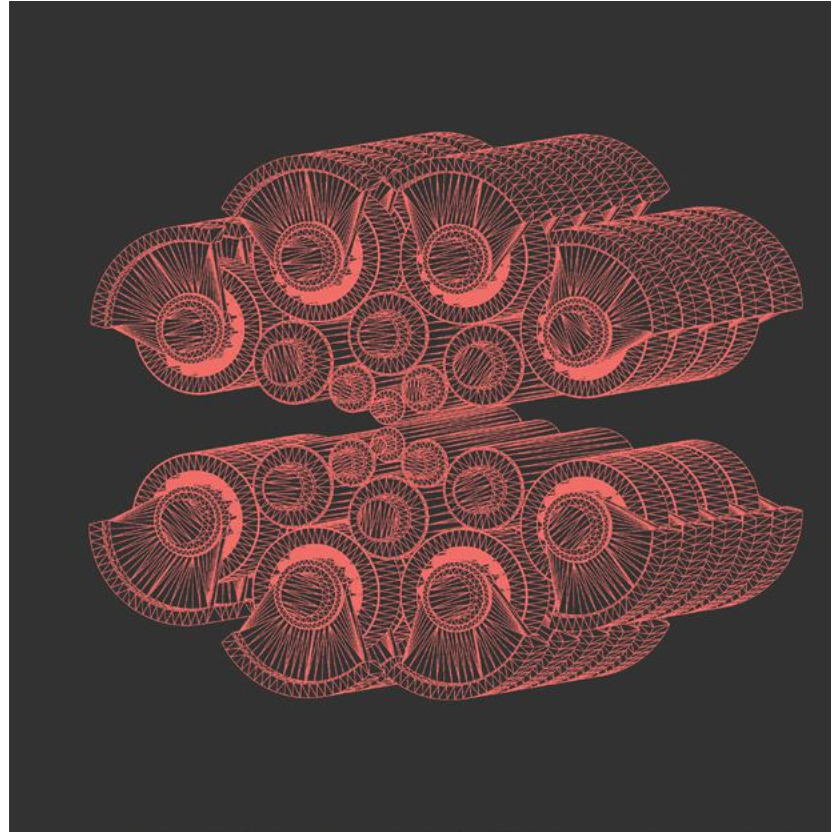





SENDZIMIR BACK-UP ROLL

Sendzimir cold rolling mill

These bearings are expertly designed and meticulously manufactured to guarantee unparalleled rolling precision. They are selected and supplied in sets to ensure geometric uniformity and ease of assembly. With this level of precision, you can achieve the highest quality standards for your rolled products, even in the harshest conditions characterized by extreme loads and temperatures. They are made with high-strength steels with high content of alloying elements.



BACK-UP ROLL Steel levelers or straighteners

These bearings are designed to support the rolling mill cylinders in flatteners or levelers. They are bearings designed to work even at high speeds and are available with both full roller complement and radial cage designs.



BACK-UP ROLL Steel levelers or straighteners

These double-execution bearings are specifically designed to support rolling mill cylinders in flatteners or levelers. The double execution allows for better distribution of pressure over the rolling cylinder, limiting wear and reducing the deformation of the shaft.



BACK-UP ROLL Steel levelers or straighteners

These shaft-less backup rollers are ideal for heavy load applications due to their full roller complement design, which maximizes their load-carrying capacity. They are primarily used for carbon steel rolling, even for large thicknesses.

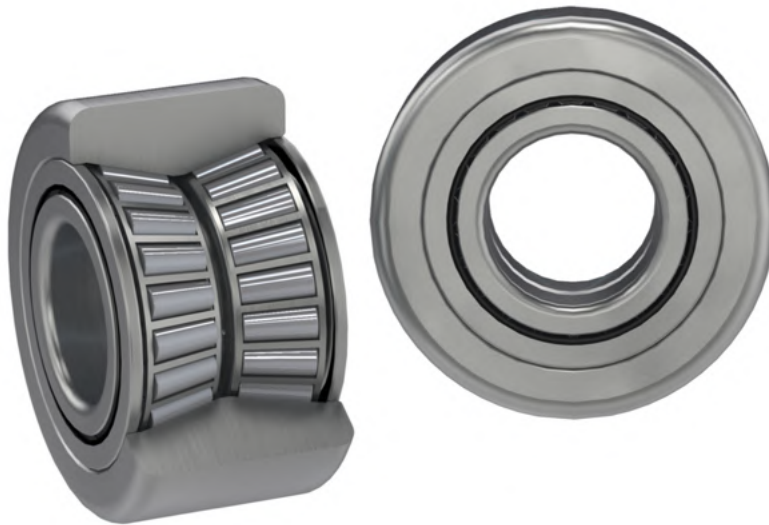

BACK-UP ROLL Steel levelers or straighteners

This type of bearings is suitable for very heavy-duty working conditions, characterized by both radial and axial loads, thanks to their ability to endure misalignments.



BACK-UP ROLL Tension leveler

These bearings are specially designed to minimize resistance torque during rotation, enabling them to maintain their load-carrying capacity even at very high rotational speeds. They are available with channels for centralized lubrication systems.



THRUST BEARINGS

Tension leveler

These bearings support the ends of the rolling mill rolls against the axial and radial loads produced during the rolling process, resulting in a superior quality of the rolled metal sheet.



MULTIROLL Hot Rolling mill

Multi-row cylindrical roller bearings are mainly used at the end of rolling mill cylinders. Despite their compact design, they have an extremely high radial load capacity due to the large number of raceways. They are available in various designs to meet all your specific requirements.



BACK-UP ROLL Linear Handling- Flying Shear

Combined bearings paired with specific profiles are an ideal choice for linear movement of even very heavy loads. They can be customized to withstand harsh environmental conditions.

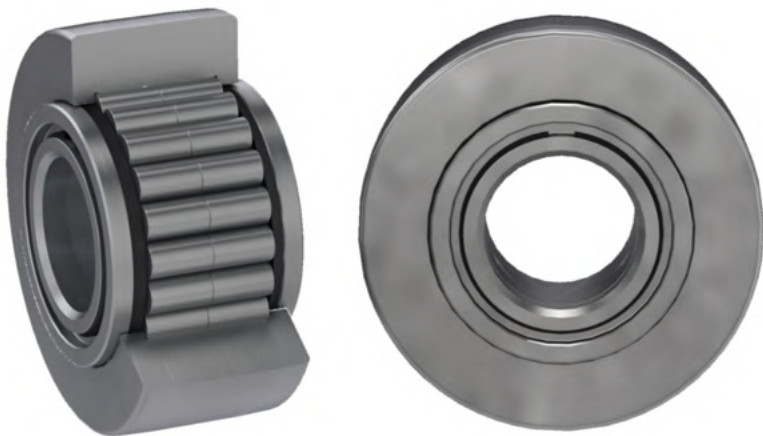

CONVEYOR TRACK ROLLERS

Coil conveyor

These bearings function as wheels for coil conveyors. The outer ring can be manufactured with different profiles to adapt to various types of conveyor systems.

VIRTUAL VISIT



At LI-BE, we're passionate about pushing the boundaries of bearing manufacturing. Our state-of-the-art facilities and expert team allow us to create innovative solutions for the most challenging applications.

And now, you can explore our reality from anywhere in the world with just a scan of the QR code. No app needed, just open your browser and step into our world of precision engineering.





+39 0385 272419 · www.li-be.com · info@li-be.com

S.S. 10 - Loc. Fabbrica, 46 - Arena Po (PV), 27040, Italy